

RF front-end considerations for SDR ultra-wideband communications systems

Design an efficient RF front-end for a novel impulse radio signal transmission with a detection scheme of an ultra-wideband software-defined radio with high data rate demodulation structure.

By Stéphane Paquelet , Christophe Moy and Louis-Marie Aubert

The conventional design approach for software-defined radio (SDR) receivers tends to minimize the RF analog front-end by transposing RF processing in the digital domain as much as possible. However, this approach is no longer appropriate for impulse ultra-wideband (UWB) applications because of bandwidth constraints and consequently the required sampling and processing frequencies as well as associated power consumption. For this reason, it is necessary to rethink the problem. In addition, UWB imposes specific constraints for features like low-cost designs and optimized run-time performance (i.e. low power consumption).

The best way to address these issues is to perform fast and complex processing in an analog passive front end and provide the digital SDR part with reduced-bandwidth signals. Hence, the following characteristics are required for the front end:

- Passive analog front-end (low cost and low power consumption).
- Easy-to-integrate.
- Pre-processing that only extracts the necessary metrics (i.e. sufficiently informative statistics to solve essential questions such as detection and transmission issues).
- Adequate bandwidth for low-cost analog-to-digital converter (ADC) and realistic digital processing speed.
- Relaxed synchronization means.
- Multiple usage of the same RF front-end output for several applications managed by SDR.

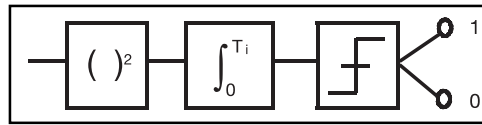

Figure 1. Non-coherent elementary receiver

■ Multiband support for high data rates (each band having convenient characteristics for SDR capabilities) in a way that allows for parallelization of the subsequent digital processing.

Thus, based on a non-coherent energy de-

detector, an original demodulation scheme was designed and investigated for a multiband on-off keying modulation system. For this receiver, channel estimation constraints were relaxed and suitable signal processing schemes were developed with requisite hardware architecture derived. Only approximate delay spread and energy levels are needed, and the associated optimum demodulation turns out to be a non-trivial energetic threshold comparison. We have analytically computed the solution

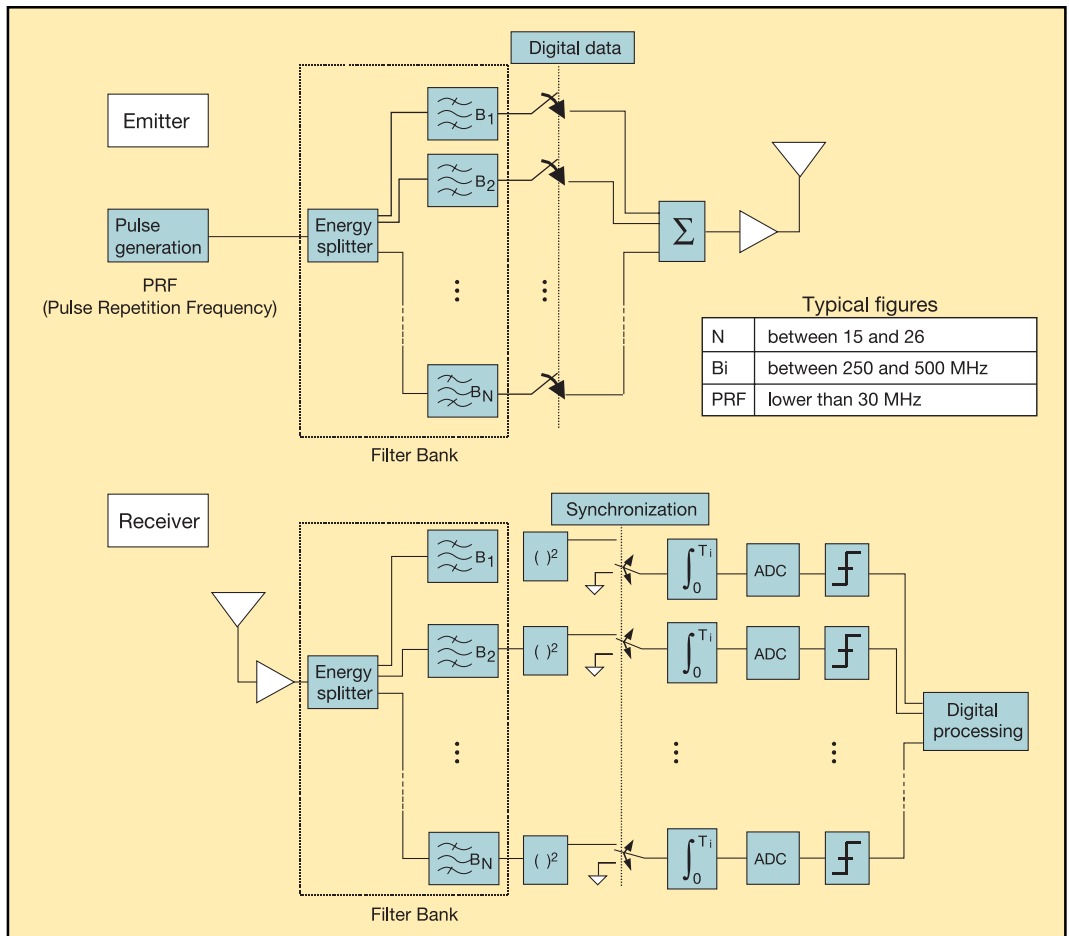

Figure 2. Transmitter and receiver functional block diagrams.

Enabling the Future of Wireless



CENTURION WIRELESS ANTENNAS INTERNAL

Accelerate your design cycle with Centurion's internal and external wireless device antennas. Centurion will design, develop and manufacture the optimal antenna to meet your specifications, on schedule, without compromise. Centurion antennas are utilized in all types of wireless devices, from industrial portable terminals to consumer grade WLAN access points.

With integrated research, design, tooling, molding, assembly and accelerated life testing facilities around the world, our engineers will quickly and efficiently create solutions to your wireless challenges.

Visit www.centurion.com to accelerate your new product development!



North America: 800.228.4563
International: 402.467.4491
www.centurion.com
sales@centurion.com



Circle 34 or visit freeproductinfo.net/rfd

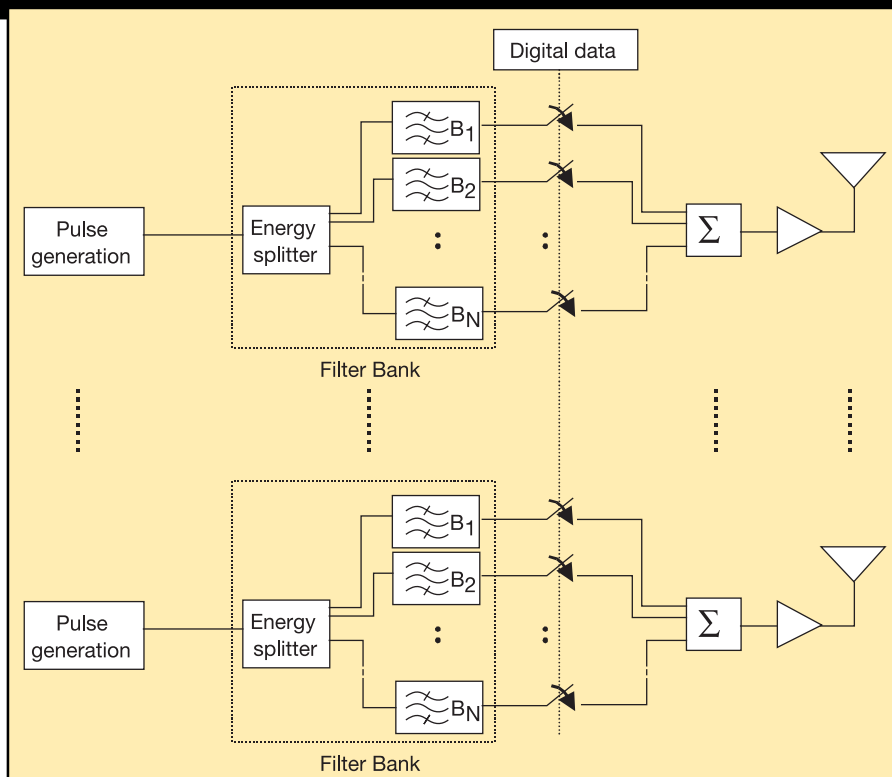

Figure 3. Transmitter with multiple pulsers, energy splitters and antennas.

For a high data rate impulse radio scheme, the elementary symbol information was carried within a single pulse duration of T_w , which is around one nanosecond.

to demonstrate its feasibility.

Physical constraints imposed by the transmission channel

For a high data rate impulse radio scheme, the elementary symbol information was carried within a single pulse duration of T_w , which is around one nanosecond. To achieve a high data rate at low-cost, complex equalization processes were eliminated to avoid inter-symbol interference. Thus, the symbol repetition period T_r is chosen such as $T_r \approx 3 T_d$, where T_d is the delay spread of the channel. Favoring non-coherent demodulation, and thus a receiver working as an energy detector, information is preferably carried by signal amplitude rather than its phase. Consequently, it leads us to consider pulse amplitude modulation (PAM). In that case, considering a non-coherent demodulation, an on-off keying (OOK) modulation appeared to be a suitable candidate. Consequently, to increase the system capacity while preserving these properties, we propose to duplicate this basic scheme on several separate sub-bands (in practice from eight to 24 bands of 250 to 500 MHz each).

Accordingly, the adopted non-coherent

receiver structure per sub-band is provided in Figure 1, where T_i denotes the energy integration time devoted to a symbol demodulation.

SDR UWB solution

Analog front-end architecture—A diagram of the transmitter and the receiver based on the above considerations is provided in Figure 2. The multiband approach that permits obtaining high data rate transmissions is illustrated. From the functional blocks shown in transmitter and receiver diagrams, it can be seen that each block can exploit state-of-the-art low cost and low-power analog technology for the front end. Digital conversion and processing requirements for SDR section are also standard.

General points—Because the approach is asynchronous, the hardware implementation is simplified. Primarily, only a coarse synchronization is needed (an error of $2 \text{ ns} \ll T_i \approx 40 \text{ ns}$ is acceptable), which makes the system robust against the clock jitter and every triggering inaccuracy. Secondly, because the processing is based on energy, the transceiver performances are nearly insensitive to distortion and phase non-linearities of

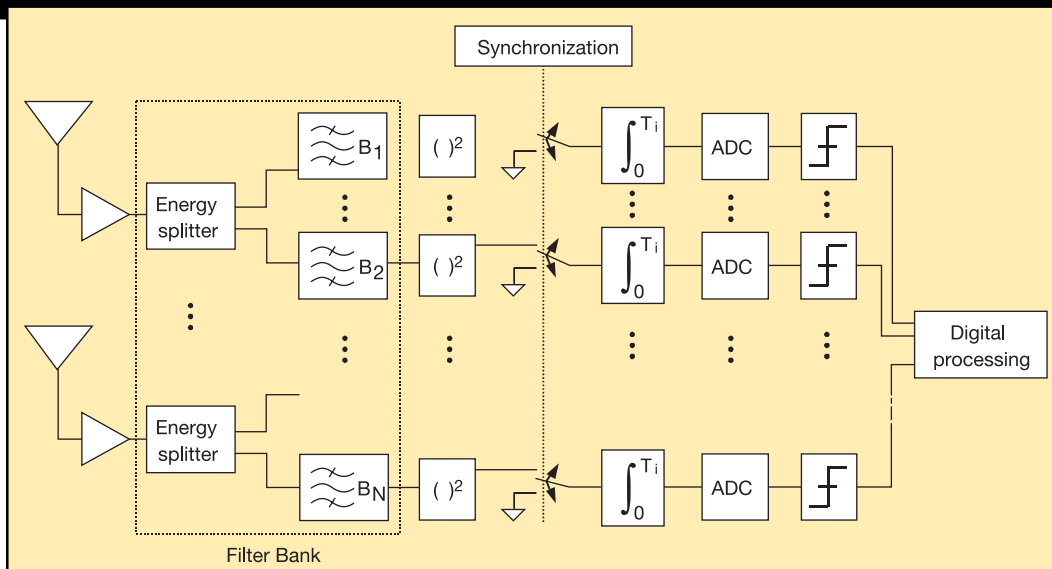

Figure 4. Receiver with multiple antennas and energy splitters.

devices like antennas, amplifiers or filters. Finally, low-power consumption is achieved, thanks to the use of mainly analog and passive devices.

Transmitter—The transmitter architecture uses a filter bank of as many as 24 adjacent filters. At the input of this filter bank, a UWB pulse (covering the whole 3.1–10.6 GHz bandwidth) is generated with a repetition period of T_r . On each line, the relatively

narrowband (from 250 to 500 MHz) pulses are modulated by an OOK modulation at the rate of $1/T_r$.

Conversely, a second solution uses a bank of local oscillators, ensuring the frequency transposition toward each sub-band. Notice that oscillators are only used to provide transposition. Coherence is not required. And the OOK modulation controls the activation of each oscillator. In this solution, the constraint

on the pulse width generated is relaxed (2 ns for 500 MHz bandwidth).

In both sketches, each narrowband pulse is added to produce a UWB signal that is transmitted through the antenna. An interesting feature to notice here is that the architecture offers a simple power control in each sub-band. This kind of flexibility can be useful to fulfill a regional power spectral density mask.

Energy splitters and combiners used in the bands of 3.1–10.6 GHz are readily available on the shelves. A

solution based on diplexers needs more development.

With regard to the switches that provide the OOK modulation, the concern is not the switching times, which are lenient, but the insertion loss. These are also easily available in the market.

As for the antenna, the issue is its bandwidth that must cover the entire 3.1 – 10.6 GHz bandwidth. Because this design uses energy to process signals, the signals are insensitive to phase and distortion. Therefore, to implement the functional scheme described above, taking into account the physical constraints, we could consider M antennas—each of them followed by a filter bank of N filters, with $N \times M$ typically equal to 24. For example, in a realistic implementation, six antennas working in a range of 1 GHz could each be followed by four filters of 250 MHz. This kind of antenna's form factor is compatible with the overall system integration.

Moreover, to ease constraints on both pulsers and energy splitters, a solution based on multiple pulsers is envisioned. In the previous example, each of the six pulsers feeds a splitter that distributes the energy over the four filters as illustrated in Figure 3.

Receiver—On the receiver side, a filter bank splits the signal in the same sub-bands as the transmitter. Then on each parallelized stage, a square law device and an integrator follow, the output of which is sampled at a rate of $1/T_r$ before demodulation.

The constraints on the antenna and the multiband distribution are the same as those encountered on the transmitter.

Concerning the quadratic detectors, many solutions are conceivable for the square law devices and the required wide working band is not a problem. Additionally, the constraints on the integrators are also relaxed since the input signals are now baseband (with bandwidth between 250 and 500 MHz). The inte-

800-522-2253

**This Number
May Not Save
Your Life...**

But it could make it a lot easier!
Especially when it comes to
ordering non-standard connectors.

RF/MICROWAVE CONNECTORS

- Specials our specialty virtually any SMA, N, TNC, BNC, SMB, or SMC delivered in 2-4 weeks
- Cross reference library to all major manufacturers.
- Large inventory of piece parts for all types of coaxial connectors.
- Experts in supplying "hard to get" RF connectors.
- Connectors supplied to your drawings and specs.
- Our 56 Standard adapters can satisfy virtually any combination of requirements, between SMA, TNC, N, 7mm, BNC and others.
- Extensive inventory of passive RF/Microwave components including attenuators, terminations and dividers.

NEMAL

RF/Microwave Connectors
for the Electronics Industry

NEMAL ELECTRONICS INTERNATIONAL, INC.

12240 N.E. 14TH AVENUE
NORTH MIAMI, FL 33161

TEL: 305-899-0900 • FAX: 305-895-8178

E-MAIL: INFO@NEMAL.COM

URL: WWW.NEMAL.COM

Circle 36 or visit freeproductinfo.net/rfd

With advances in process technology, it is possible to integrate both these functions on a single chip.

grators have to be able to integrate these signals over a time period of 10 to 50 ns. With advances in process technology, it is possible to integrate both these functions on a single chip.

As the solution envisioned for this RF front end is purely analog with passive components, the reciprocity of the device enables us to use the same structure for both transmission and reception. Consequently, the same structure with multiple antennas and energy splitters is possible as shown in Figure 4.

Digital SDR architecture

Analog-to-digital conversion—Since digitizing the overall SDR bandwidth at a rate of several gigahertz is expensive and power consuming, many current solutions are considering the use multiple sub-band processing for high data rates. In fact, even a set of 500 or 250 MHz bands to digitize is not compatible with a realistic UWB solution because it imposes a sampling rate of few hundreds of megahertz.

Since only a small part of the signal in each channel is required to compute the detection, we opted for the energy detection scheme in this design. Consequently, in our system, it only requires us to sample the received signal every time the delay spread is a few tens of megahertz, typically 30 MHz. The use of multiple sub-bands in this case is only justified to speed up the data rate of the information. Each band must only keep sufficient wideband characteristics to provide the receiver with enough multipath to benefit from the diversity offered by the channel. Channel analysis has shown that a 500 MHz, or even 250 MHz band, respects these requirements.

Moreover, only a reduced resolution in terms of number of bits is necessary, which eases the digital processing of the SDR system. The number of bits required depends on the accuracy expected when estimating the received energy (required to set the threshold). A number of four to eight bits can be used during the estimation procedure. Once the threshold is set, an analog decision could be even envisaged, that is to say, having a one-bit resolution. However, an ADC conversion on a few bits during this stage can be useful to adapt the threshold according to the channel variation or to make soft decoding.

As a conclusion, the proposed architecture for high data rates only requires a simultaneous digitization on each sub-band (24 as an example) at a rate of a several tens of megahertz with a resolution of one to a few bits. A reduced system can cope with low data rates while adjusting the number of sub-

bands to each case.

Synchronization and MAC—Relaxed synchronization methods based on asynchronous time-hopped signal detection have also been investigated to enable fast channel delay spread estimation. From a system point of view, usual *medium access control* (MAC) is being re-visited, taking benefit from energy detection techniques while FDMA division may favor the inherent frequency separation properties in such a system.

Performance—Analytical performances of the system discussed have been computed and show remarkable results [1]. These results are obtained without channel coding techniques, which can be added later for even better performance. As shown in Table 1, corresponding throughputs are 150 Mbps at 10 meters for a 10^{-5} bit error rate on different types of IEEE 802.15.3a channel models (CM) under FCC transmission mask. Data rates of 600 Mbps at 3 meters are affordable with the use of 24 sub-bands of 250 MHz.

Note that the proposed system can be dimensioned accordingly to the usage demand in terms of data rate.

Indeed, comparison with coherent systems show that, to compete with our on-off keying scheme, a classical rake receiver for a coherent BPSK should collect up to 40 percent of the whole available energy. This is challenging due to severe multipath characteristics for typical UWB impulse radio signals and should hardly be achievable at the same cost of the solution proposed in this article.

SDR benefits to this UWB solution

In essence, an SDR UWB solution is only conceivable in the context of relaxed sampling constraints that can make SDR support a technical reality with limited requirements

It is believed that in a majority of cases, an impulse radio modulation, especially for high data rates, implies a coherent detection.

in terms of power consumption and hardware component costs. The combination of UWB and SDR is promising in the context of our UWB design because the information provided by the analog part can be efficiently used in different systems. This approach will enable cost savings by drastic reduction of design time and minimization of the number of hardware platforms as the same analog information can support low data rate trans-

R*	150	240	600	Mbit/s
d	10	5	3	m
B	500	500	250	MHz
N _{band}	12	12	24	
T _r	80	50	40	ns
CM	4	3	2	
T _i	50	40	30	ns
P _e *	10 ⁻⁵	10 ⁻⁵	10 ⁻⁵	

Table 1. Performance data for high throughputs.

mission, high data rate transmission, localization as well as channel sounding operations. SDR capabilities may also be used to change some behavior of the system at runtime to adapt the system to its environment or to new system features [2].

Acknowledging the fact that different types of UWB applications necessitate algorithmic adaptations not only at the physical layer but throughout the protocol stack, the SDR approach will also help in efficiently supporting the different protocol stack configurations within a generic UWB hardware platform. This may be a particularly interesting feature in the context of ad-hoc networking which is one of UWB's potential targets.

Finally, considering the difficulties met at the IEEE UWB standardization body where several solutions are considered and seem to be inevitable at the end, SDR is a solution that may work with the different proposals currently being discussed in the United States and in the near future in a European standard body. To be precise, our impulse radio UWB solution can cope with any impulse radio scheme based on a multiband approach.

Conclusion

Impulse radio UWB technology implementation is facing such difficulties that the UWB community seems to support more traditional schemes, e.g. OFDM or wideband DS-CDMA. It is believed that in a majority of cases, an impulse radio modulation, especially for high data rates, implies a coherent detection. This consequently leads to RAKE

receiver designs for dense multipath conditions associated with complex equalization procedures, necessitating heavy synchronization and channel estimation phases. Obviously, these challenging issues prompted designers toward well-known schemes to quickly answer the market's demand.

Nevertheless, it is possible to consider realistic constraints of the receiver at the early stage of the design, while investigating the

best way to use an impulse radio signal with coarse synchronization techniques. This is what studies made at Mitsubishi Electric ITE-TCL research lab demonstrated. It permitted the construction of an efficient RF front end for a novel architecture with promising features such as impulse radio signal acquisition (detection and synchronization) and high data rate demodulation structure. RFD

Acknowledgment

The authors would like to thank their colleagues Apostolos Kountouris and Alexis Bisiaux for their contribution to the SDR

ABOUT THE AUTHORS

Stephane Paquelet graduated from the Ecole Polytechnique (1996) and the ENST-Paris (1998). He previously worked at Thales as a cryptologist and Dassault Electronique in the field of electronic warfare (signal processing). He joined Mitsubishi Electric ITE-TCL in 2002, where his current research deals with UWB systems. His main interests are applied mathematics and physics. His background on UWB includes supervising patents on non-coherent modulation/demodulation schemes and fast detection/synchronization methods on time-hopping codes. He can be reached at paquelet@tcl.ite.mee.com

Christophe Moy is an engineer of the INSA (National Institute of Applied Sciences), Rennes, France, 1995. He received his M.Sc. and Ph.D. degrees in Electronics in 1995 and 1999 from the INSA. He worked from 1995 to 1999 on spread-spectrum and RAKE receivers for the IETR (Institute on Electronics and Telecommunications of Rennes). He has been working for five years at Mitsubishi Electric ITE-TCL research lab. He is focusing on software radio systems and concepts, including digital signal processing, HW and SW architecture, codesign methodology and reconfiguration and applying them to the design of SDR UWB systems. Moy represents Mitsubishi Electric at the SDR Forum and works on a French research program on SDR called A3S. He can be reached at moy@tcl.ite.mee.com

Louis-Marie Aubert received B.S. and M.S. degrees in electronic and communications system in 2002 from the INSA of Rennes. He is now working toward the Ph.D. degree in the Mitsubishi Electric Telecommunication Laboratory in collaboration with IETR-INSA. His field of interest is the signal processing applied to the ultra-wideband systems. He can be reached at aubert@tcl.ite.mee.com.

issues of this paper, as well as Gwillerm Froc and INSA-IETR members Bernard Uguen and Jean-Baptiste Dore for their contribution on UWB.

References

1. "An Impulse Radio Asynchronous Transceiver for High Data Rates," Stéphane Paquelet, Louis-Marie Aubert and Bernard Uguen, Mitsubishi ITE-TCL, Rennes, France; IETR-INSA, Rennes, France; 2004 Interna-

tional Workshop on Ultra Wideband Systems Joint with Conference on Ultra Wideband Systems and Technologies, Kyoto; May 18-21, 2004

2. "HW and SW Architectures for Over-The-Air Dynamic Reconfiguration by Software Download," Christophe Moy, Apostolos Kountouris, Alexis Bisiaux Mitsubishi ITE-TCL, Rennes, France; in Proc. SDR Workshop of the IEEE RAWCON '2003, Boston, United States, August 2003.

No Speed Limit





Performance with Class

Fine-tune your sample rate up to 400 MS/s and get the most out of the new 12-bit digitizer technology from Acqiris.

With our new V-Class high-resolution digital technology, you'll achieve unequalled measurement precision, signal fidelity and throughput.

Superior hallmark features such as Acqiris' unique Ctrl I/O and ASBus front-panel ports for clock and trigger distribution make system integration quick and easy.

As a result, you'll reach your measurement and automation objectives in no time and get products to market faster.

The new high-resolution Cougar for frequency domain applications features bandwidths up to 300 MHz (via direct HF input) and sampling rates fine-tunable up to 400 MS/s with resolutions better than 500 kS/s, and up to 4 Mpoints of memory per channel.



Ideal for wideband frequency-related measurements in radar I/Q demodulation and wireless communication

HRes SR

HF In

ASBus

Ctrl I/O





For more information, call us at 1 877 227 4747 or visit our website at www.acqiris.com